



Exclusief dealer (vanaf 1972!) in de Kop van Noord-Holland van het bekende kwaliteitsmerk **Linde**.

Vestiging Dirkshorn

Industrieterrein De Banne
C. de Vriesweg 3-5
1746 CL Dirkshorn
T 0224-551387
F 0224-552068
E info@vandersluisbv.nl
I www.vandersluisbv.nl

Vestiging Anna Paulowna

Spoorsingel 17
1761 EA Anna Paulowna
T 0223-531644
F 0223-532762
E info@jvandersluis.nl
I www.jvandersluis.nl

Naast de verkoop van intern transport materieel van het merk Linde beschikken wij ook over een verhuurvloot van dit kwaliteitsmerk. Ons bedrijf hanteert voor zowel de korte als langere termijn speciale tarieven voor de verhuur van Linde intern transport materieel.

Steeds meer bedrijven maken gebruik van de mogelijkheid om gedurende piekperiodes of in het oogstseizoen of andere drukke tijden heftrucks of andersoortig intern transport materieel te huren. Voor elke toepassing is een geschikt transportmiddel voorhanden.

Bezoek onze website www.jvandersluis.nl voor meer informatie of neem contact met ons op via bovenstaande telefoonnummers en e-mail adressen.



Features



Safety

- Three independent braking systems.
- Emergency circuit isolator.
- Keyswitch.
- Fail-to-safe circuitry.
- Traction isolated by seatswitch and/or hand-brake.
- Comprehensive warning lights.
- Electric horn.
- Full road lighting.
- Excellent all-round visibility.
- Electrical overload protection.

Standard equipment

All items as shown under safety.
Four wheel configuration.
80V circuit.
Left or right hand drive steering position.
Tractor without cab.
Single pedal accelerator and direction lever.
Hydrostatic power steering.
Full suspension PVC driver's seat.

Non-suspension PVC passenger seat.

Pneumatic tyres.
5 kW drive motor.
AC controller with regenerative braking.
Comprehensive integrated display.
Trailer lighting socket.
Dual circuit hydraulic disc brakes on all four wheels.
Standard colour scheme – vermilion and charcoal grey.

Batteries and chargers

80V, 210 to 320 Ah to DIN 43536A.
72V, 210 to 320 Ah.
A range of chargers is available to suit application and main supply requirements.

Optional equipment

Cab with front and rear screens, wipers and washers, and two exterior mirrors:
– without sides or
– with flexible roll up sides or
– hinged doors.

Electric or diesel heater and demister.
High torque (20 kW) drive motor - only with 320 Ah battery.
72V circuit.
Rear lights mounted high at rear of cab.
Flashing or rotating beacon on cab.
Reverse warning bleeper.
Contoured solid (superelastic) tyres.
Towing couplings:
– Automatic single position, front and/or rear.
– Automatic single position, remote, rear.
– Multi-position, front and/or rear.
240 mm rear coupling extension.
Remote inching control.
Aluminium lift-out side panels.
Hinged aluminium side panels with or without flexible cover and framework.
Fabric covered seats.
Heated seats.
Full suspension passenger seat.
Alternative key switch types.
Alternative colour schemes.
Other options available on request.

The manufacturer reserves the right to alter specifications without notice. DM5109A/12/03

Electric platform tractor 2.0 t



W 20
TrActive

Introduction

The four wheel electric platform tractor model W 20 TrActive is available with either a 2200 mm or 2600 mm long platform, and has been developed to suit a wide range of industrial and municipal applications including distribution, manufacturing, hospitals, postal services, airports and fruit and vegetable markets.

The design makes the tractor particularly adaptable by the use of a variety of specialist attachments. It has the dual capability of carrying 2 tonne on the platform and towing nominal loads of 4.5 tonne when optional towing attachment is fitted.

The overall design concept ensures excellent driver comfort contributing significantly to high work throughput with minimum fatigue.

Features

- Compact design for optimum manoeuvrability.
- Ergonomically designed driver's compartment for optimum comfort, safety and efficiency.
- Energy saving electronic AC control with regenerative braking for smooth operation and increased productivity.
- High performance AC drive motor for increased work throughput.

Driver's compartment and controls

A low step facilitates access. The tractor can be supplied with or without cab. The cab can be supplied with a number of options and is mounted to the chassis on hydraulically damped isolated mounts which reduce vibration and noise. The tractor is available with left or right hand drive steering position. The automotive arrangement of the pedals,

steering wheel and controls, plus full suspension driver's seat, contribute to comfort and operational efficiency. A non-suspension passenger seat is also fitted. The single pedal accelerator and direction lever, together with electronic AC control, ensures smooth operation. Comprehensive integrated display includes hour meter, battery discharge indicator, brake/hydraulic fluid level, lighting, indicators, motor temperature and speed.

Chassis

The chassis has been designed to achieve maximum strength and rigidity, and provides protection for all components, with ease of access for maintenance.

A low centre of gravity ensures safe road holding under all operating conditions.

A hinged door is provided to enable side-ways removal/replacement of the battery by independent lifting equipment.

Transmission and suspension

A powerful AC drive motor integrated with the drive axle transmits power to the rear wheels through reduction gearing. The front wheels have parabolic leaf spring suspension with hydraulic dampers and the rear axle is mounted via trailing links, coil springs and hydraulic dampers.

Electrical system

The tractor is fitted with an advanced 80V, energy saving electronic AC control system which incorporates regenerative braking and provides smooth acceleration for safe, precise manoeuvring.

A high number of work cycles can be obtained from each battery charge due to

the efficiency of this system of energy control. Integrated diagnostics, via a CAN bus connection, enable rapid servicing and maximum uptime.

Steering

Energy saving, on demand hydrostatic power steering powered by an AC motor requires minimum steering effort, ensuring excellent manoeuvrability and operational efficiency.

Platform

The generously proportioned platform, available in two lengths, has a comfortable loading height and can be easily adapted to suit specific types of load.

Lighting

The 12V, full road lighting circuit is powered by an isolated DC/DC converter. The two front, recessed dipping headlights are fitted with integral sidelights and separate direction indicators. The rear light clusters incorporate rear lights and reflectors, brake stop lights, direction indicators, reversing light and fog light. Hazard warning lights and a number plate light are also fitted. An external seven pin lighting socket is provided to give 12V power for trailer lights.

Braking

The tractor has three independent braking systems:

1. Dual circuit hydraulic disc brakes on all four wheels with hydraulic booster.
2. Hand lever operated parking brake mechanically connected to rear wheels.
3. Electrical regenerative braking occurs by progressive release of accelerator pedal.

Linde Material Handling (UK) Ltd.,
Kingsclere Road, Basingstoke, Hampshire RG21 6XJ.
Tel: 01256 342000. Fax: 01256 342923. Web: www.linde-mh.co.uk
E-mail: enquiries@linde-mh.co.uk
For more information please contact your nearest national network company on **0845 608 5000**



Certificate No. FM 342



LINDE		Platform tractor		Data sheet for material handling equipment		127		VDI 2198	
DECEMBER 2003		Designation		to VDI 3586		Series no.		Registration note	
Manufacturer's data and design characteristics				Model types					
Characteristics	1.1	Manufacturer		Linde		Linde			
	1.2	Model designation		W 20 (2 200)		W 20 (2 600)			
	1.3	Power unit: battery, diesel, petrol, LP gas, mains power		Battery		Battery			
	1.4	Operation: manual, pedestrian, stand-on, seated, order picker		Seated		Seated			
	1.5	Carried load capacity	Q (t)	2		2			
	1.7	Rated drawbar pull, with/without carried load	F (N)	500/900 ¹⁾	800/1 200 ¹⁾	500/900 ¹⁾	800/1 200 ¹⁾		
Weights	1.9	Wheelbase	y (mm)	1 900		1 900			
	2.1	Service weight	kg	3 100		3 200			
	2.2	Axle load with load, front/rear	kg	2 300/2 800		2 100/3 100			
Wheels and tyres	2.3	Axle load without load, front/rear	kg	1 800/1 300		1 800/1 400			
	3.1	Tyres, front/rear (SE = CS superelastic, P = pneumatic)		P/P ²⁾		P/P ²⁾			
	3.2	Tyre size, front		6.00 R 9		6.00 R 9			
	3.3	Tyre size, rear		7.00 R 12		7.00 R 12			
	3.5	Wheels, number front/rear (x = driven)		2/2x		2/2x			
	3.6	Track width, front	b ₁₀ (mm)	1 080		1 080			
	3.7	Track width, rear	b ₁₁ (mm)	1 020		1 020			
Dimensions	4.7	Height of overhead guard (cabin)	h ₆ (mm)	1 820		1 820			
	4.8	Height of seat/stand-on platform	h ₇ (mm)	745		745			
	4.12	Towing coupling height, minimum/maximum	h ₁₀ (mm)	240, 295, 350, 405		240, 295, 350, 405			
	4.13	Platform height, without load	h ₁₁ (mm)	840		840			
	4.16	Loading platform, length	l ₃ (mm)	2 200		2 600			
	4.17	Rear overhang	l ₅ (mm)	730		1 130			
	4.18	Loading platform, width	b ₉ (mm)	1 300		1 300			
	4.19	Overall length	l ₁ (mm)	3 530		3 930			
	4.21	Overall width	b ₁ (mm)	1 300		1 300			
	4.32	Ground clearance, centre of wheelbase	m ₂ (mm)	150		150			
Performance	4.35	Turning radius	W _a (mm)	3 280		3 280			
	4.36	Minimum pivoting point distance	b ₁₃ (mm)	1 095		1 095			
	5.1	Travel speed, with/without carried load	km/h	15/20	20/25	15/20	20/25		
	5.5	Drawbar pull at 60 minute rating, with/without carried load	N	500/900	800/1 200	500/900	800/1 200		
	5.6	Maximum drawbar pull, with/without carried load (on level ground)	N	5 600/6 000 ¹⁾	9 600/10 000 ¹⁾	5 600/6 000 ¹⁾	9 600/10 000 ¹⁾		
	5.7	Climbing ability, with/without load, 30 minute rating	%	See graph		See graph			
Drive	5.8	Maximum climbing ability, with/without load, 5 minute rating	%	See graph		See graph			
	5.10	Service brake		Hydraulic/electric		Hydraulic/electric			
	6.1	Drive motor, 60 minute rating	kW	5 ⁵⁾	20 ⁵⁾	5 ⁵⁾	20 ⁵⁾		
	6.3	Battery according to DIN 43531/35/36 A, B, C, no		DIN 43536A		DIN 43536A			
	6.4	Battery voltage/rated capacity (5 h)	V/Ah	80/320 ⁴⁾⁵⁾		80/320 ⁴⁾⁵⁾			
	6.5	Battery weight (±5%)	kg	858		858			
Other	6.6	Power consumption according to VDI cycle	kWh/h	3)		3)			
	8.1	Type of drive control		AC - microprocessor		AC - microprocessor			
	8.4	Noise level at operator's ear	dB (A)	3)		3)			
		8.5	Towing coupling, design/type, DIN/no	3)		3)			
<p>1) Based on level, dry surface with rolling resistance of 200 N/t. Refer to graph opposite for specific operating conditions and when the application involves inclines or ramps.</p> <p>2) Contoured solid (superelastic) tyres are available.</p> <p>3) Refer to manufacturer for figures.</p> <p>4) 72 V circuit is available. Traction speed is reduced by 10%.</p> <p>5) High torque 20 kW motor is available in conjunction with 320 Ah battery only.</p>									

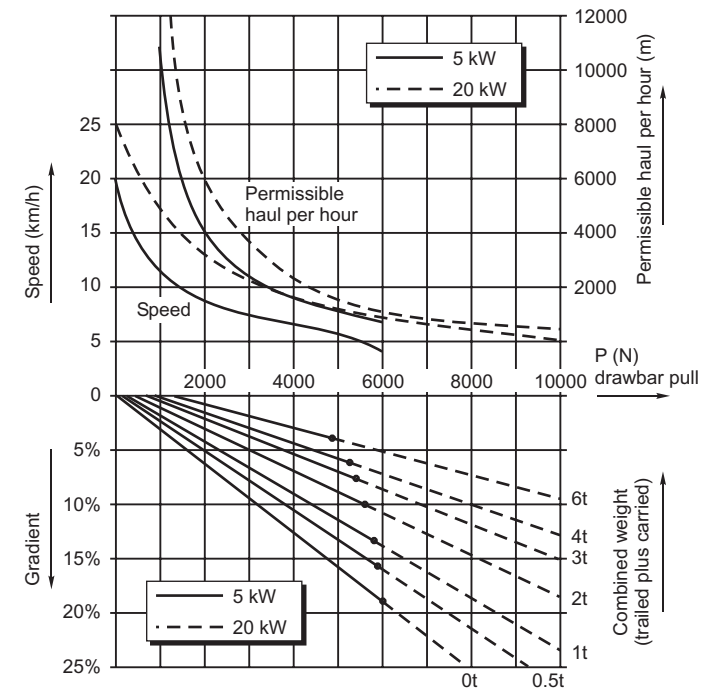
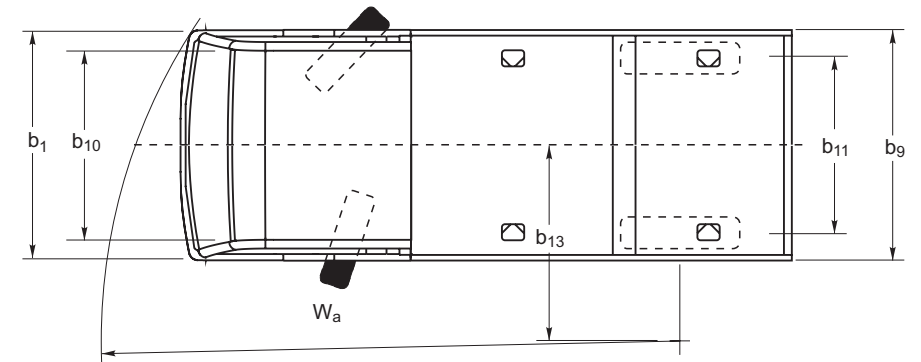
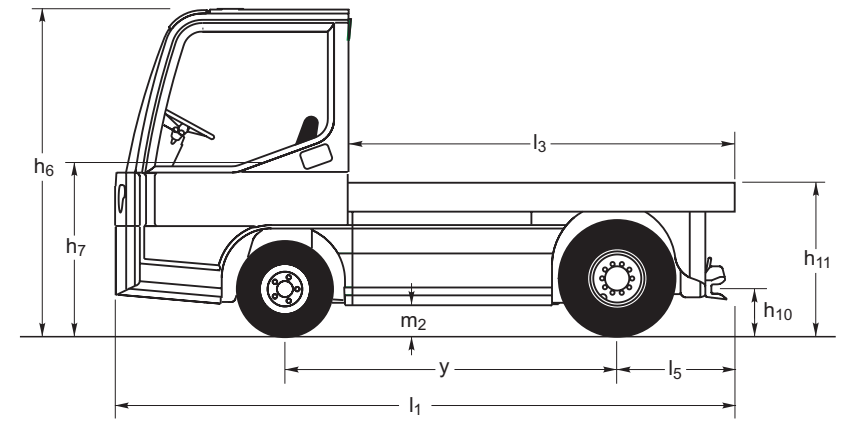

The permissible haul per hour is the total distance travelled, including the return journey, and any downhill gradients.

It is recommended that braked trailers are used for all trailer loads if gradients are involved.