



Exclusief dealer (vanaf 1972!) in de Kop van Noord-Holland van het bekende kwaliteitsmerk **Linde**.

Vestiging Dirkshorn

Industrieterrein De Banne
C. de Vriesweg 3-5
1746 CL Dirkshorn
T 0224-551387
F 0224-552068
E info@vandersluisbv.nl
I www.vandersluisbv.nl

Vestiging Anna Paulowna

Spoorsingel 17
1761 EA Anna Paulowna
T 0223-531644
F 0223-532762
E info@jvandersluis.nl
I www.jvandersluis.nl

Naast de verkoop van intern transport materieel van het merk Linde beschikken wij ook over een verhuurvloot van dit kwaliteitsmerk. Ons bedrijf hanteert voor zowel de korte als langere termijn speciale tarieven voor de verhuur van Linde intern transport materieel.

Steeds meer bedrijven maken gebruik van de mogelijkheid om gedurende piekperiodes of in het oogstseizoen of andere drukke tijden heftrucks of andersoortig intern transport materieel te huren. Voor elke toepassing is een geschikt transportmiddel voorhanden.

Bezoek onze website www.jvandersluis.nl voor meer informatie of neem contact met ons op via bovenstaande telefoonnummers en e-mail adressen.





Pedestrian Tow tractor Capacity 5000 kg P 50

SERIES 131

Linde Material Handling

Linde

Safety

The low chassis skirt ensures that the wheels remain safely within the truck contours. Together with the rounded, smooth shape of the chassis and tiller head, this reduces all risk of pinching or snagging.

Performance

Powered by an 1.5 kW AC motor, the P 50 accelerates fast to reach a 6 m/h full speed. Its 5,000 kg capacity and efficient brakes enable a productive work for heavy duties.

Comfort

The electric steering gives a smooth and efficient control of the tractor. The operator manoeuvres comfortably and his tasks are eased thanks to dedicated compartments to store his working tools. All controls can be operated with either hand without ever having to let go of the tiller.

Reliability

The robustness of the tiller head, the strong hooking system and the high quality pressed steel frame is always something that you can rely on.

Service

Efficiency at work, efficiency at the cost level. CAN bus connection enables all truck data to be read out for inspection when servicing becomes due at intervals of 1,000 operating hours. Easy accessibility of all components and the maintenance free AC technology employed play an additional part in keeping truck uptime up.

Technical data (According to VDI 2198)

Characteristics	1.1	Manufacturer		LINDE
	1.2	Model designation		P50
	1.3	Power unit: battery, diesel, petrol, LP gas, mains		Battery
	1.4	Operation: manual, pedestrian, stand-on, seated, order picker		Pedestrian
	1.5	Load capacity	Q (kg)	5000
	1.7	Rated drawbar pull	F (N)	850
	1.9	Wheelbase	y (mm)	810 ²⁾
Weights	2.1	Service weight	(± 10 %) kg	810 ¹⁾
	2.3	Axle load without load, drive side/load side	(± 10 %) kg	495/315 ^{1) 2)}
Wheels/Tyres	3.1	Tyres: solid rubber (R), polyurethane (P)		R+PP
	3.2	Tyre size, front	mm	Ø 254 x 102
	3.3	Tyre size, rear	mm	Ø 250 x 80
	3.4	Auxiliary wheels (dimensions)	mm	Ø 100 x 40
	3.5	Wheels, number drive side/load side (x = driven)		1x+2/2
	3.6	Track width, front	(± 5 mm) b10 (mm)	544
	3.7	Track width, rear	(± 5 mm) b11 (mm)	650
Dimensions	4.9	Height of tiller arm in operating position, min/max	h14 (mm)	1140/1350
	4.12	Towing coupling height	h10 (mm)	300, 290/345/400
	4.19	Overall length	(± 5 mm) l1 (mm)	1165 ²⁾
	4.21	Overall width	(± 5 mm) b1/b2 (mm)	790/736
	4.32	Ground clearance, centre of wheelbase	(min) m2 (mm)	30
	4.35	Turning radius	(min) Wa (mm)	1045 ²⁾
	4.36	Minimum pivoting point distance	b13 (mm)	1160 ²⁾
Performance	5.1	Travel speed, with/without load	(± 5 %) km/h	6/6
	5.5	Drawbar pull (60 minutes rating)	N	850
	5.6	Maximum drawbar pull	N	3100
	5.7	Climbing ability	%	-
	5.8	Maximum climbing ability	%	-
	5.9	Acceleration	(sur 10 m) s	9,3 / 7
	5.10	Service brakes		Electromagnetic
Drive	6.1	Drive motor (60 minutes rating)	kW	1.5
	6.3	Battery according to IEC		DIN 43535 B
	6.4	Battery voltage/rated capacity (5 h)	(± 10 %) V/Ah	24/375
	6.5	Battery weight	kg	295 ¹⁾
	6.6	Power consumption according to VDI cycle	kWh	-
	Others	8.1	Type of drive control	
8.4		Sound level at operator position	dB (A)	< 70
8.5		Towing coupling, design/type, DIN		-

1) With battery: line 6.4

2) With a 3 PzS Lateral (+100 mm for 3 PzS Vertical and 4 PzS Lateral; +150 mm for 4 PzS Vertical)

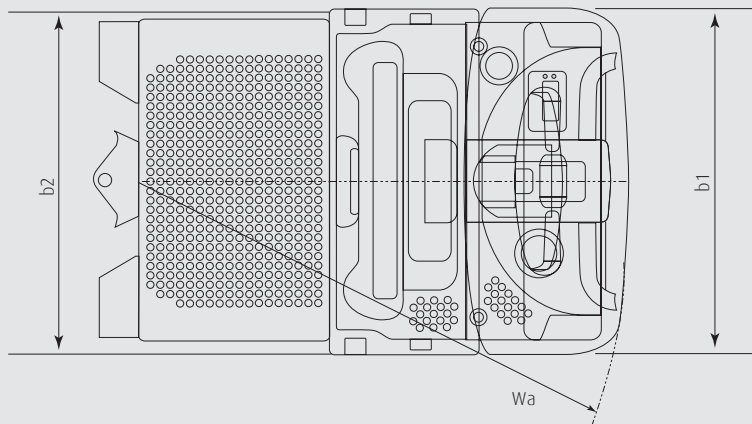
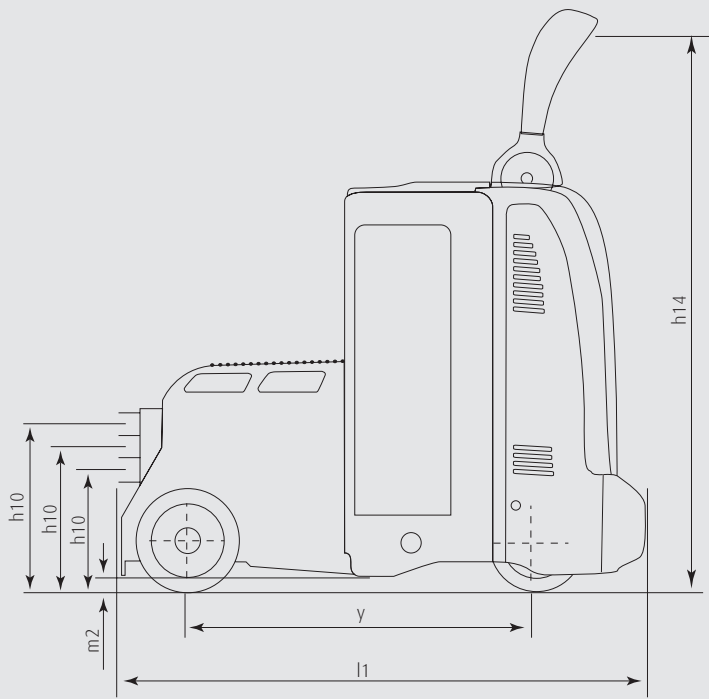

Example of application

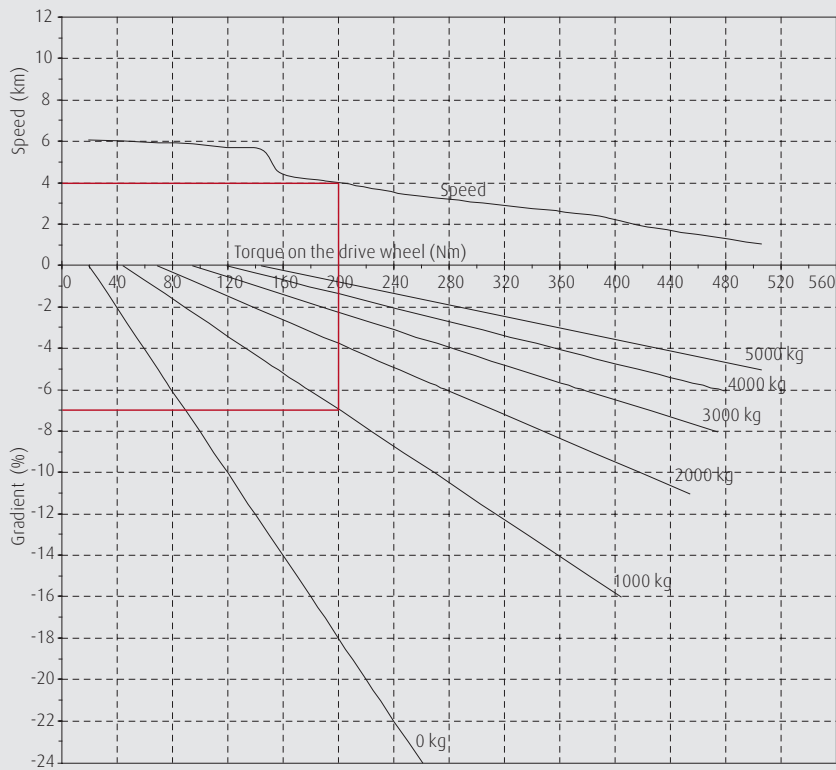

The Example shown above illustrates	
A tractor towing	1 t load
Operating on a ramp of	7%
Maximum travelling speed reachable	4 km/h



Equipment

Standard equipment

Multifunction back lighted display	Automatic braking
Key switch or Log in Pin code: ignition	Electromagnetic emergency brake acting proportionally to the load weight
Cushion drive wheel	Single position hook (300 mm)
Dedicated work station (with storage compartments)	Horn
Power assisted steering (drive wheel) feedback	Protection -10°C
Automatic speed reduction when cornering	
AC motor	

Optional equipment

Drive wheel: polyurethane, cushion non-marking or wet grip	Fixed battery stand for side battery change
Different hooking system	Cold store version to -35°C
Clipboard	
Support for data terminal or barcode reader (centre)	Other options available on request.

Features



CAN bus architecture

- Electronic management of all components permitting quick and easy diagnosis
- All performance parameters can be configured exactly by the service technician for every individual mission

Equipments & Hook system

- Support for data terminal or barcode reader (centre)
- Roomy compartment in the back (50 liters)
- Hook control (inching) on both sides enable a soft and safe hanging
- Different hooks available: Single position and 3 positions

Batteries for every need

- Vertical battery change as standard, optional side battery change left or right
- Wide range batteries: from 270 Ah (3 PzS) to 500 Ah (4 PzS)
- Battery locking system for side change option secures battery in compartment and eases the battery change

Brakes

- Automatic braking on release of the controls
- Counter-current braking
- The emergency stop button is electromagnetic on the drive motor and proportional to the load transported



Work station

- Digital and multifunction display
- Truck activated by PIN code or by ignition key
- Wide and deep storage compartments in front and centre for wrapping paper, work gloves, writing utensils, etc.
- Adjustable backrest in height to provide comfortable and secure driving position

AC motor

- Powerful and smooth 1.5 kW at 100 % performance
- Moisture and dust-proof motor, maintenance-free
- No rollback on uphill starting
- Maximum speed of 6 km/h, whenever the truck is loaded or unloaded
- A maximum drawbar pull of 305 daN

Power steering

- Proportional power-assisted steering, effortless to operate
- Adjustable steering feedback (drive wheel) resulting in efficient stability
- Automatic speed reduction when cornering
- Manoeuvring effort vary depending on the turning angle

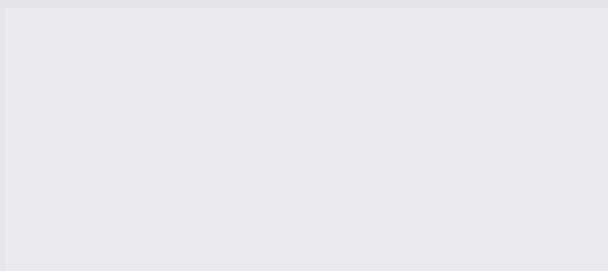

Linde AG

Linde Material Handling Division, Postfach 10 01 36, 63701 Aschaffenburg, Germany
Phone +49.60 21.99-0, Fax +49.60 21.99-15 70, www.linde-forklifts.com, info@linde-forklifts.com



Linde Material Handling

Linde

Subject to change in the interests of progress. Illustrations and technical details non-binding. All dimensions subject to customary tolerance.

Printed in Germany - 095 - e - 2 - 0206 - Ind. A - Co